

Boiler with manual loading

OPOP
partner for your heating

H4 EKO-D, H4 EKO-D S

The intelligent wood gasification boiler combines classic heating with modern technologies that guarantee its high efficiency with low fuel consumption. The minimum external dimensions of the boiler allow placement even in small spaces without the need for structural modifications. The large hopper extends the burning time of the fuel per load and thus reduces the frequency of loading.

The boiler is equipped with a control unit that controls the combustion process and an exhaust fan that regulates the output.

The unique flat hot concrete burning surface ensures high-quality fuel burning without arching.

The loading door is a robust construction to ensure a perfect seal without smoke leakage. Thanks to the spring system, these door can be opened and closed very easily.

Cleverly solved flue gas extraction during loading thanks to the exhaust flap.



A+

ECO
DESIGN

5-YEAR
WARRANTY

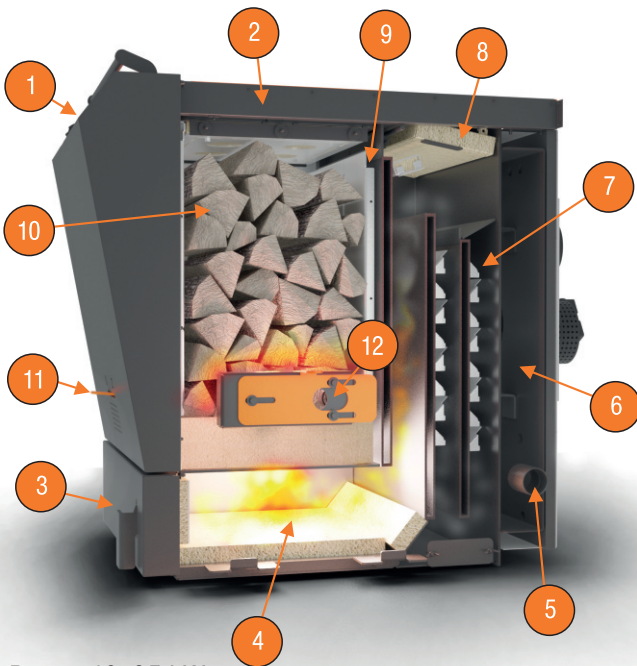

1. **Control unit** with intuitive control in the front part of the boiler.
2. **Large loading door** for easy fuel loading.
3. **Ashtray door** for removing ashes.
4. Combustion chamber lined with hot concrete bricks for minimal emissions.
5. **Heating spiral well** for heating the heating water using electricity.
6. **A cooling loop** protecting the boiler against overheating in the event that it is more than 95°C on the boiler.
7. Compact **boiler exchanger**, ensuring high efficiency.
8. **Cleaning door** for access to the boiler exchanger.
9. **An exhaust flap** that sucks smoke from the hopper and thus prevents smoke from escaping into the room during wood loading.
10. **The loading shaft** can hold a large amount of wood.
11. **Secondary air flap** set to mark will ensure low emissions and high wood burning efficiency.
12. **Primary air flaps** on both sides of the boiler. They ensure adequate boiler performance when set to the mark. They help in warming up if they are opened to the maximum.

Power: 16–25 kW

Fuel: wood, chopped / H₂O max. 20%

Easy operation

- Very small dimensions of the boiler due to the power range from 16 kW to 25 kW. For example, the 16 kW boiler version is only 50 cm wide and 96 cm high. It fits into very small spaces without the need for structural modifications.
- The boiler has a large hopper in relation to the overall size of the boiler, which can hold a large amount of wood for one load. The volume of the loading chamber is from 42 to 82 l depending on the power and the length of the logs from 33 to 40 cm.
- The unique flat hot concrete bottom of the loading chamber makes it possible to create a large hot layer, which ensures high-quality fuel burning for long hours and without vaulting.
- The loading door is robust to ensure a perfect seal without smoke leakage. Thanks to the spring opening system, handling them is very easy.
- A smart solution for extracting flue gas during loading – the boilers are equipped with an exhaust flap that ensures smoke is sucked into the chimney
- Reduction of tarring in the loading chamber – part of the primary combustion air is brought to the upper part of the loading chamber in order to prevent the condensation of vapors in the hopper and thus reduce tarring.
- The boiler includes a cooling loop that protects the boiler from overheating.
- Easy maintenance and cleaning thanks to simple access to the heat exchanger.

Economical and ecological operation

- The boiler has a high efficiency of up to 90.2%, which means efficient use of fuel energy.
- Low wood consumption together with a large hopper reduce the frequency of fuel loading.
- Low electricity consumption
- The accumulation tank will reduce the frequency of filling even more. Connecting the storage tank is a condition for the correct operation of the boiler.
- It satisfies into the 5th emission class and meets the conditions of ecodesign.
- High-quality combustion produces very low emissions even without the use of a lambda probe or other devices.

Long life

- Long-life electronic elements are used in the boiler.
- 5-year warranty on the heat exchanger when the boiler is installed by a trained installation company in accordance with the operating instructions.
- Loading chamber protection - the loading chamber of the boiler is equipped with shielding plates that protect the heat exchanger from the effects of fumes created in the combustion chamber.

Accessories

- The hydraulic set simplifies the installation of OPOP boilers and thus shortens the time required to connect the boiler to the heating system.
- The Internet module connects the boiler with an application that continuously monitors the operation of the boiler and stores its activity history. Designed for H4EKO-D version only.

Possibility of connection	H4 EKO-D	H4 EKO-D S
CH pump	YES	YES
DHW pump	YES	YES (with Modul EU +1 TUV)*
Additional pump	YES	YES (with Modul EU +1 TUV)*
Pump of mixing valve 1	YES	YES (with Modul EU +1 TUV)*
Pump of mixing valve 2	YES (with Modul EU +1 TUV)*	YES (with Modul EU +1 TUV)*
Mixing valve 1	YES	YES (with Modul EU +1 TUV)*
Mixing valve 2	YES (with Modul EU +1 TUV)*	YES (with Modul EU +1 TUV)*
Storage tank	YES (with temp. sensor)	YES (with temp. sensor)
Ekviterm controll	YES	YES (with Modul EU +1 TUV)*
Room thermostat RT10 /other thermostat	YES	YES (with Modul EU +1 TUV)*
Internet/mobile app control	YES (with internet. modul)	NO
Boiler temperature sensor	YES	YES
Safety sensor	YES	YES
Hot water sensor	YES	YES (with Modul EU +1 TUV)*
Mixing valve sensor	YES	YES (with Modul EU +1 TUV)*
Storage tank sensor	YES	YES
Outside temperature sensor	YES (with sensor)	YES (with Modul EU +1 TUV)*
Fan	Modulated fan speed	On/Off operation
Electronic detection of fuel in hopper	YES	NO
Ability to maintain steady glow layer	YES	NO
Electronic control unit	Control boiler and all elements of heating system	Can control boiler, pump, DHW and storage tank

* Modul EU +1 TUV- optional accessories

Technical parameters		H416 EKO-D / H416 EKO-D S	H420 EKO-D / H420 EKO-D S	H425 EKO-D / H425 EKO-D S
Nominal heat output	[kW]	16	20	25
Efficiency	[%]	90	90	90,2
Required operation draft	mbar	12	12	12
Weight	[kg]	265	317	369
Ekodesign		yes	yes	yes
Class of the boiler EN 303-5		5	5	5
Water volume	[l]	33	44	54
Flue diameter	[mm]	130	130	130
Fuel consumption	[kg/hod]	4,1	5,1	6
Heating water temperature range	[°C]	65 - 85	65 - 85	65 - 85
Loading chamber volume	[l]	42	62	82
Dimensions of loading door (depth x width)	[cm]	35 x 22	35 x 32	35 x 42
Log length	[cm]	33	33	40
Duration of burning at nominal output	[hod]	> 4	> 4	> 4
Flue gas temperature at nom. heat. output	[°C]	137	130	130
Maximum overpressure of heating water	[MPa]	0,2	0,2	0,2
Test overpressure of heating water	[MPa]	0,4	0,4	0,4
Water content in fuel	[%]	H ₂ O max. 20%	H ₂ O max. 20%	H ₂ O max. 20%
Electrical coverage	IP	20	20	20
Power consumption in standby mode/max	[W]	4/38	4/42	4/44
Voltage supply	[V/A]	230/2	230/2	230/2
Boiler hydraulic loss at Δ T = 20 K	mbar	0,2	0,3	0,5
Noise	dB	42,3 ± 3,2 dB		

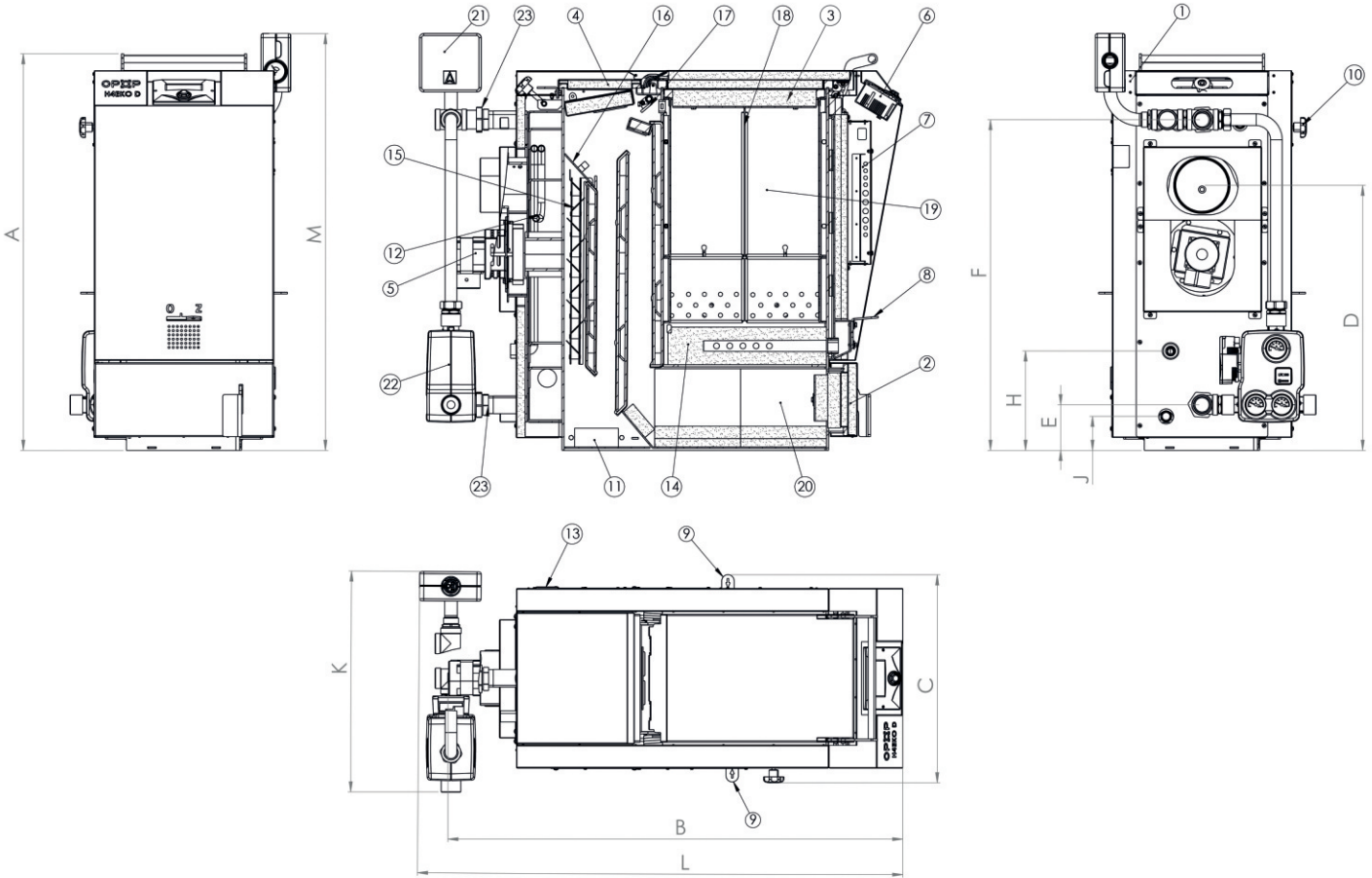

Position	Part Name
1.	Main switch
2.	Ashtray door
3.	Loading door
4.	Cleaning door
5.	Exhaust fan
6.	Control unit display
7.	Box with electronic

Position	Part Name
8.	Secondary air regulation
9.	Primary air regulation
10.	Smoke damper control
11.	Cleaning hole
12.	Cooling loop
13.	Socket for electric heating element
14.	Fired concrete nozzle

Position	Part Name
15.	Flue gas turbulator (H416EKO-D 1x; H420EKO-D 1x; H425EKO-D 2x)
16.	Cleaning flap
17.	Smoke damper
18.	Protective plates of the loading shaft
19.	Filling shaft
20.	Combustion chamber

Position	Part Name
21.	Afriso safety group (hydraulic set components)*
22.	ESBE LTC includes pump + mixing module (hydraulic set components)*
23.	Fitting (hydraulic set components)*

* Must be ordered separately.

		H416 EKO-D / H416 EKO-D S	H420 EKO-D / H420 EKO-D S	H425 EKO-D / H425 EKO-D S
Socket outlet / inlet (external thread)		G1 1/4"	G1 1/4"	G1 1/4"
Connecting the cooling loop (internal thread)		G 1/2"	G 1/2"	G 1/2"
Connection for draining and filling (internal thread)		G 1/2"	G 1/2"	G 1/2"
A – total height of the boiler	[mm]	964	964	964
B – total depth of the boiler	[mm]	1085	1085	1085
C – boiler width	[mm]	498	598	698
D – location of the flue	[mm]	635	635	635
E – location of inlet water nozzle	[mm]	109	109	109
F – location of outlet water nozzle	[mm]	791	791	791
H – location of the cooling loop	[mm]	238	238	238
I – location of the heating element	[mm]	173	173	173
J – drain valve location	[mm]	77	77	77
K – width of the hydraulic set	[mm]	528	528	528
L – total depth with hydraulic set	[mm]	1158	1158	1158
M – height of boiler with hydraulic set	[mm]	998	998	998
Boiler body wall thickness (water/flame)		5	5	5